



河北雄安盛蕴科技有限公司

HEBEI XIONGAN SHARE TECHNOLOGY CO., LTD



Manual Pallet Truck

SY-M-PT



Short introduction:

- ✔ A hydraulic forklift, also known as a hydraulic lift truck, is a forklift that operates by introducing pressurized liquid. Hydraulic forklifts use a hydraulic system to lift or lower items and travel on wheels or tracks.
- ✔ Hydraulic lift trucks have many advantages, such as Strong load-bearing capacity, Safe and stable operation, environmental protection and energy saving.
- ✔ It can be widely used in warehouses, docks, ports and other places, especially in the field of heavy cargo transportation and loading and unloading.



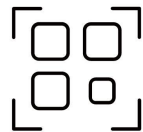

Ergonomic handle:

- * Spring-loaded safety loop handle
- * 3-function hand control operation: raise, neutral, lower.

Oil Cylinder Integral Casting:

Integrated cylinder reinforced seal good performance no oil leakage.

PU /nylon wheels:

Four Back Wheels Smooth and Steady, different wheels for you to choose, smooth handling and no bumps.





Specifications

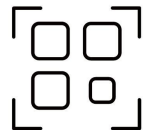
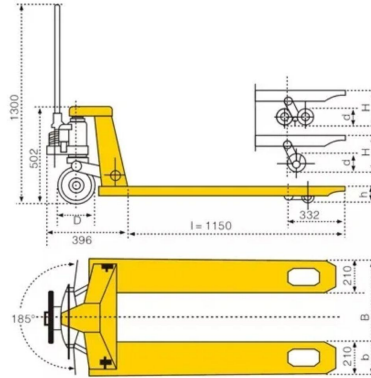



Specifications

Model	SY-M-PT-02	SY-M-PT-2.5	SY-M-PT-03
Capacity (kg)	2000	2500	3000
Min. fork height (mm)	85/75	85/75	85/75
Max. fork height (mm)	195/185	195/185	195/185
Lifting height (mm)	110	110	110
Fork length (mm)	1150/1220	1150/1220	1150/1220
Single fork width (mm)	160	160	160
Width overall forks (mm)	550/685	550/685	550/685

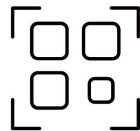



Factory



Punch Equipment



Robot Welding



Powder Coating Workshop



Accessories Storage Workshop



Assembling



Finished Product Display

Wide Application



CONSTRUCTION SITE



PORT AND PIER



FACTORY WAREHOUSE



UNLOADING HANDLING

