



河北雄安盛蕴科技有限公司

HEBEI XIONGAN SHARE TECHNOLOGY CO., LTD



Micro Electric Stacker

SY-E-MES



Short introduction:

✔ Electric pallet stacker is an efficient, safe and green logistics equipment.

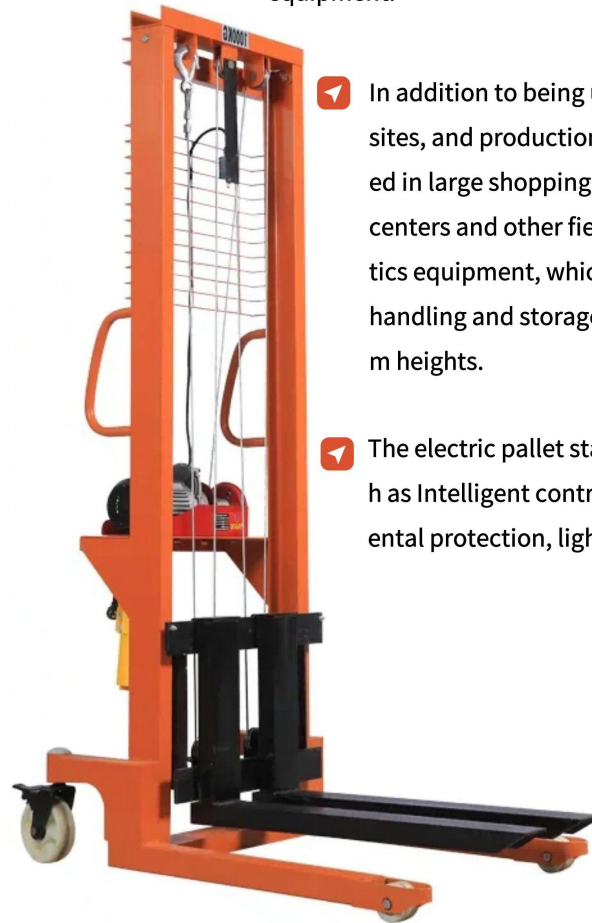

✔ In addition to being used in warehousing, logistics sites, and production lines, it can also be widely used in large shopping malls, supermarkets, logistics centers and other fields. It is a kind of electric logistics equipment, which is mainly used for stacking, handling and storage of goods with low and medium heights.

✔ The electric pallet stacker has many advantages, such as Intelligent control, energy saving and environmental protection, lightweight and easy to operate.





Omni-directional wheels:

Nylon/PU wheel can be rotated for 360 degree.

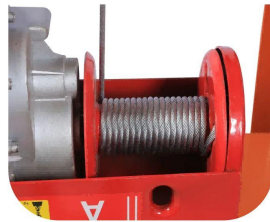

Pure copper motor:

Strong input power and efficient operation.



Reinforced fork:

Forged manganese steel forks strong bearing capacity, suitable for various pallets.

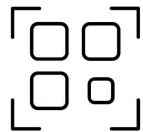



Specifications 

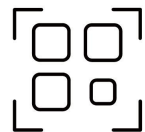
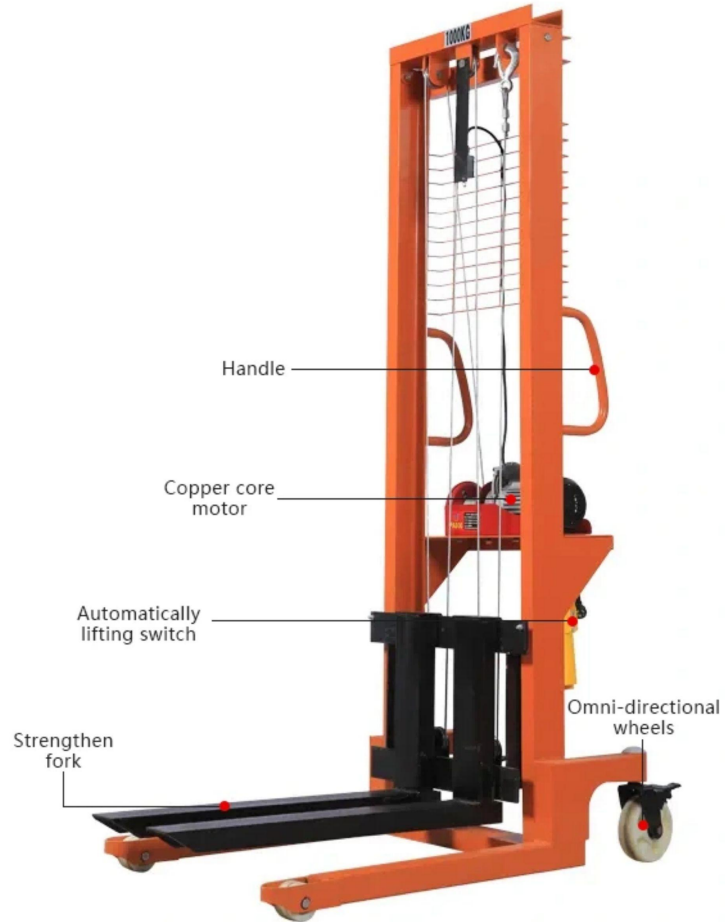



Specifications

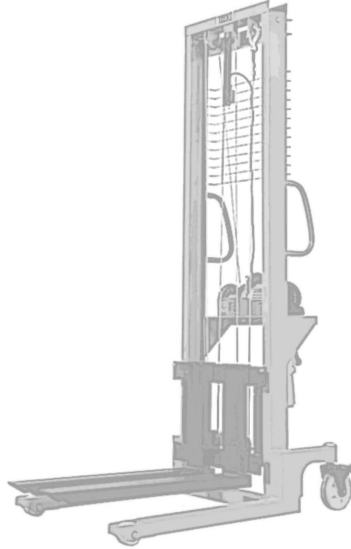

Model	Rated load	Lifting height	Fork length(mm)	Fork width(mm)	size(mm)			Front/ back wheel dia	NW
					L	W	H		
SY-ES-01CH	1T	1.6m	840	100	1350	705	2080	50*90mm/50*180mm	≈137kg
SY-ES-01C	1T	1.6m	1000	140	1580	890	2100		≈167kg
SY-ES-02C	2T	1.6m	1000	140	1580	890	2100		≈190kg
SY-ES-02I	2T	1.6m	830	120	1410	702	2090		≈175kg
SY-ES-03I	3T	1.6m	1000	140	1250	800	2110		≈252.5kg

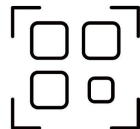



Transport 



Wide Application 



CONSTRUCTION SITE



PORT AND PIER



FACTORY WAREHOUSE



UNLOADING HANDLING

