



河北雄安盛蕴科技有限公司

HEBEI XIONGAN SHARE TECHNOLOGY CO. LTD



Semi-electric Pallet Truck

SY-SE-PT



Short introduction:

- ✔ Lead acid battery electric pallet jack is commonly used in warehouses, factories, and distribution centers for moving and transporting heavy loads over short distances.
- ✔ The lead-acid battery semi-electric pallet truck is an efficient, environmentally friendly, and reliable handling equipment.
- ✔ Low maintenance delivers increased productivity and reduced operational costs.



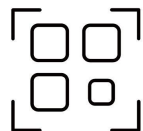

Emergency Stop Switch Button:

Optional universal wheel, excellent stable chassis configuration.

Universal Wheel:

Optional universal wheel, excellent stable chassis configuration.

Alloy-Iron Body:

Formed heavy gauge steel provides maximum fork strength and longevity, durable and reliable. Ditch the plastic and adopt a crash-resistant, sturdy all-iron body.





Specifications 

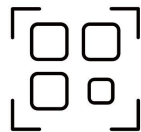
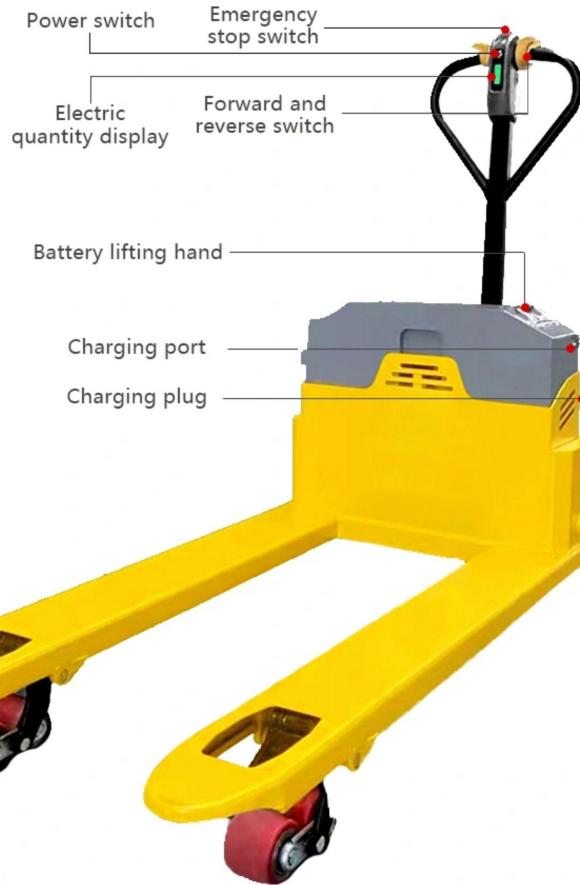
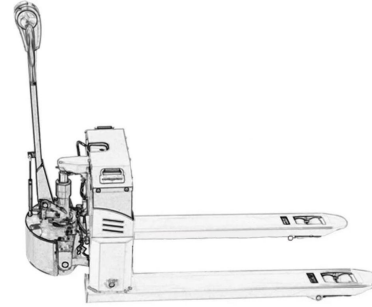



Specifications

Product Code	SY-SES20-3-550	SY-SES20-3-685	SY-ES20-2-685	SY-ES20-2-550
Battery Type	Lead Acid Battery	Lead Acid Battery	Lead Acid Battery	Lead Acid Battery
Battery Capacity	48V20Ah	48V20Ah	48V20Ah	48V20Ah
Travel Speed	5km/h	5km/h	5km/h	5km/h
Battery Ampere hours	6h	6h	6h	6h
Brushless Permanent Magnet Motor	800W	800W	800W	800W
Load Capacity(kg)	3000kg	3000kg	2000kg	2000kg
Frame Sizes (mm)	550*1200	685*1200	550*1200	685*1200
Fork Length(mm)	1200mm	1200mm	1200mm	1200mm
Min Fork Height(mm)	70mm	70mm	70mm	70mm
Max Fork Height(mm)	200mm	200mm	200mm	200mm
Dead Weight(kg)	150kg	155Kg	175kg	170Kg

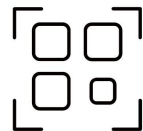



Factory



Wide Application

