

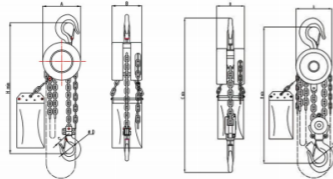

HSS-A 型不锈钢手拉葫芦

HSS-A type stainless steel chain hoist



- 不锈钢手拉葫芦是我公司最新研制出的产品，采用304不锈钢材质，广泛应用于海洋工程、船舶修造、海上石油平台、海洋运输。
- 可在海洋环境、腐蚀环境下使用，不锈钢手拉葫芦在出厂前经过严格的2000小时的盐水喷雾检测，具有极高的防腐特性，产品品质卓越，可放心购买使用。
- 不锈钢手拉葫芦除可单独使用外，还可同电动葫芦、链动或电动小车装配在一起悬挂在建筑物的顶棚或起重机的梁上使用。
- 也可配合单轨小车，实现左右行走提升重物的功能。
- Stainless steel hand hoist is the latest product developed by our company, using 304 stainless steel material, widely used in Marine engineering, ship repair, offshore oil platform, Marine transport.
- Can be used in the Marine environment, corrosive environment, stainless steel hand hoist before the factory after a strict 2000 hours of saline spray detection, with extremely high anti-corrosion characteristics, excellent product quality, you can rest assured to buy and use.
- Stainless steel hand hoist can be used alone, but also with electric hoist, chain or electric car assembled hanging on the roof of the building or crane beam used.
- It can also cooperate with the monorail car to realize the function of walking around and lifting heavy objects.

型号 Model	HSS-A0.5	HSS-A1	HSS-A2	HSS-A3	HSS-A5	HSS-A7.5	HSS-A10	
额定载荷 Capacity(t)	0.5	1	2	3	5	7.5	10	
起重高度 Lifting height(m)	2.5	2.5	2.5	2.5	2.5	2.5	2.5	
试验载荷 Test load(t)	0.75	1.5	3	4.5	7.5	11.2	12.5	
链条行数 No. of load chain fall lines	1	1	2	2	3	4	6	
尺寸 Dimension(mm)	A	142	178	178	266	350	360	580
	B	130	150	150	170	170	170	170
	Hmin	300	390	600	650	880	900	1000
	D	30	43	63	65	72	77	106
净重 Net weight(kg)	12	15	26	38	66	83	180	



HSS-F型不锈钢手拉葫芦(全封闭式)

HSS-F stainless steel chain hoist(Totally enclosed)

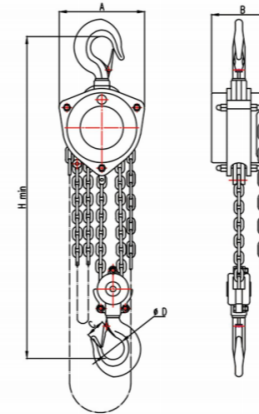

型号 Model	HSS-F0.5	HSS-F1	HSS-F2	HSS-F3	HSS-F5	HSS-F7.5	HSS-F10	HSS-F15	
额定载荷 Capacity(t)	0.5	1	2	3	5	7.5	10	15	
起重高度 Lifting height(m)	2.5	2.5	2.5	2.5	2.5	2.5	2.5	2.5	
试验载荷 Test load(t)	0.75	1.5	3	4.5	7.5	11.2	12.5	25	
链条行数 No. of load chain fall lines	1	1	2	2	3	4	6	8	
尺寸 Dimension(mm)	A	170	210	210	253	380	390	450	590
	B	130	150	150	168	168	186	186	186
	Hmin	380	450	630	670	880	900	1020	1100
	D	30	43	50	63	65	72	77	106
净重 Net weight(kg)	12	16	26	38	66	83	150	180	



HSS-F型不锈钢手拉葫芦(低净空)
HSS-F type stainless steel chain hoist(Low headroom)

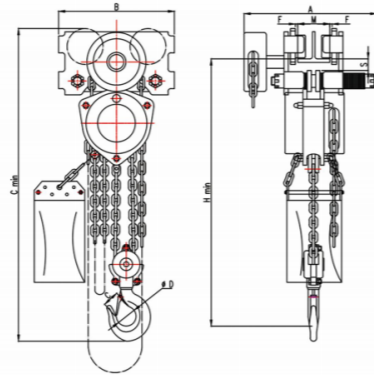

型号 Model	HSS-F 0.5	HSS-F 1	HSS-F 2	HSS-F 3	HSS-F 5	HSS-F 7.5	HSS-F 10	HSS-F 15
额定载荷 Capacity(t)	0.5	1	2	3	5	7.5	10	15
起重高度 Lifting height(m)	2.5	2.5	2.5	2.5	2.5	2.5	2.5	2.5
试验载荷 Test load(t)	0.75	1.5	3	4.5	7.5	11.2	12.5	25
链条行数 No. of load chain fall lines	1	1	2	2	3	4	6	8
推荐使用工字钢 I-Beam width(m)	M	75-125	75-125	100-150	100-150	125-175	124-203	125-180 136-203
尺寸 Dimension(mm)	B	245	245	275	350	380	420	420 760
	Hmin	310	380	480	650	750	755	950 1000
	D	30	43	50	63	65	72	77 106
净重 Net weight(kg)	25	32	45	60	90	130	290	390

HSS-A型不锈钢手拉葫芦(低净空)
HSS-A stainless steel chain hoist(Low headroom)

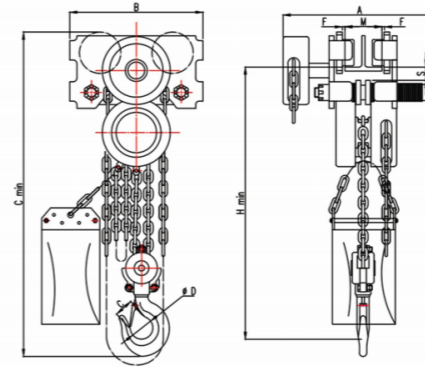

型号 Model	HSS-A 0.5	HSS-A 1	HSS-A 2	HSS-A 3	HSS-A 5	HSS-A 7.5	HSS-A 10	HSS-A 15
额定载荷 Capacity(t)	0.5	1	2	3	5	7.5	10	15
起重高度 Lifting height(m)	2.5	2.5	2.5	2.5	2.5	2.5	2.5	2.5
试验载荷 Test load(t)	0.75	1.5	3	4.5	7.5	11.2	12.5	25
链条行数 No. of load chain fall lines	1	1	2	2	3	4	6	8
推荐使用工字钢 I-Beam width(m)	M	75-125	75-125	100-150	100-150	125-175	124-203	125-180 136-203
尺寸 Dimension(mm)	B	245	245	275	350	380	420	420 760
	Hmin	310	380	480	650	750	755	950 1000
	D	30	43	50	63	65	72	77 106
净重 Net weight(kg)	25	32	45	60	90	130	290	390



河北雄安盛蕴科技有限公司

HEBEI XIONGAN SHARE TECHNOLOGY CO., LTD



GCSL型不锈钢手拉单轨小车

GCSL type stainless steel Geared trolley

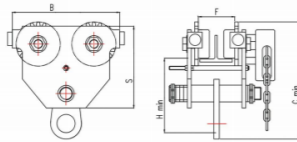

GCST型不锈钢手推单轨小车

GCST type stainless steel Push trolley

规格 Model		GCL1	GCL2	GCL3	GCL5	GCL10	GCL20
		GCB1	GCB2	GCB3	GCB5	GCB10	GCB20
额定载荷 Capacity(t)		1	2	3	5	10	20
实验载荷 Test load KN		1.5	3	4.5	7.5	15	30
标准运行高度 Standard lifting height(m)		3	3	3	3	3	3
满载时的手拉力（水平直道上） Hand pull(horizontal straight)		50	90	95	140	240	250
主要尺寸 Dimension(mm)	B	245	245	275	350	380	420
	S	170	190	220	240	265	265
	Hmin	170	190	200	210	230	320
	C	260	290	320	360	410	510
轨道宽度范围 Track width(mm)	F	90-122	102-152	110-165	122-172	130-210	130-210
净重 Net weight(kg)	GCL	15	20	26	34	51	115
	GCB	13	17	23	30	47	106



HSS-A型不锈钢手拉葫芦(组合式)

HSS-A type stainless steel chain hoist(combined)

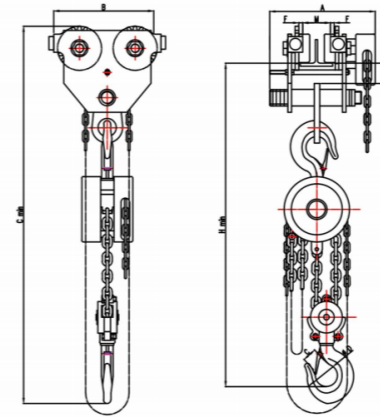

型号 Model	HSS-40.5	HSS-A1	HSS-A2	HSS-A3	HSS-A5	HSS-A7.5	HSS-A10	HSS-A15	
额定载荷 Capacity(t)	0.5	1	2	3	5	7.5	10	15	
起重高度 Lifting height(m)	2.5	2.5	2.5	2.5	2.5	2.5	2.5	2.5	
试验载荷 Test load(t)	0.75	1.5	3	4.5	7.5	11.2	12.5	25	
链条行数 No. of load chain fall lines	1	1	2	2	3	4	6	8	
推荐使用工字钢 I-Beam width(m)	M	75-125	75-125	100-150	100-150	125-175	124-203	125-180	136-203
尺寸 Dimension(mm)	B	245	245	275	350	380	420	420	760
	Hmin	470	560	790	850	1090	1130	1230	1420
	D	30	43	50	63	65	72	77	106
净重 Net weight(kg)		27	30	46	64	100	134	231	295



DHSS型不锈钢环链电动葫芦(固定式)

DHSS type stainless steel electric chain block(stationary type)

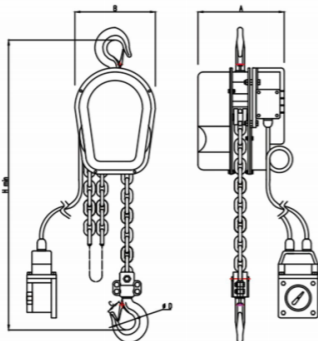

额定起重量 Rated Lifting Load	1000kg	2000kg	3000kg	5000kg	7500kg	10000kg
起升速度 Lifting Speed	2.25m/min	1.85m/min	1.1m/min	0.9m/min	0.6m/min	0.45m/min
起升高度 Lifting height(m)	3-6m	3-6m	3-6m	3-6m	3-6m	3-6m
电机型号 Motor Model	HBEY	HBEY	HBEY	HBEY	HBEY	HBEY
电机功率 Motor Power	750W	750W	750W	750W	750W	750W
电机转速 Motor Speed	1380r/min	1380r/min	1380r/min	1380r/min	1380r/min	1380r/min
电源电压 Supply Voltage	380V	380V	380V	380V	380V	380V
尺寸 Dimension(mm)	A	280	280	280	280	280
	B	275	275	275	275	340
	Hmin	520	600	680	710	850
	C	580	630	780	820	970
整机重量 Weight	3m	40kg	43kg	50kg	70kg	107kg



DHSS型不锈钢环链电动葫芦(运行式)

DHSS type stainless steel electric chain block(Running type)

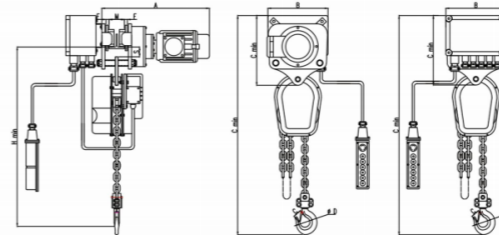

额定起重量 Rated Lifting Load	1000kg	2000kg	3000kg	5000kg	7500kg	10000kg
起升速度 Lifting Speed	2.25m/min	1.85m/min	1.1m/min	0.9m/min	0.6m/min	0.45m/min
运行速度 Running speed	20	20	20	20	10	10
起升高度 Lifting height	3-6m	3-6m	3-6m	3-6m	3-6m	3-6m
运行电机型号 Operation model of motor	HBEY	HBEY	HBEY	HBEY	HBEY	HBEY
电机型号 Motor Model	HBEY	HBEY	HBEY	HBEY	HBEY	HBEY
电机功率 Motor Power	750W	750W	750W	750W	750W	750W
电机转速 Motor Speed	1380r/min	1380r/min	1380r/min	1380r/min	1380r/min	1380r/min
电源电压 Supply Voltage	380V	380V	380V	380V	380V	380V
尺寸 Dimension(mm)	M	90-122	102-152	110-165	122-172	130-210
	B	350	350	360	400	450
	Hmin	610	640	790	830	1050
	C	580	630	780	820	970
整机重量 Weight	3m	80kg	84kg	96kg	125kg	198kg



HSSH型不锈钢手扳葫芦
HSSH type stainless steel lever hoist

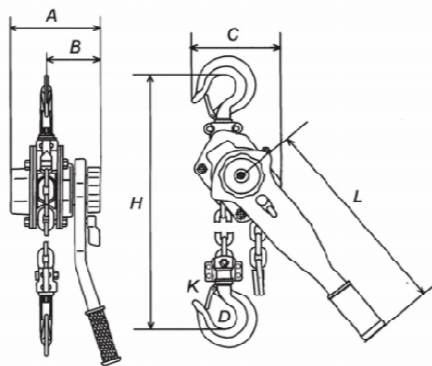

型号 Type	HSSH-0.75	HSSH-1.5	HSSH-3	HSSH-6	HSSH-9	
额定起重重量 Rated lifting weight T	0.75	1.5	3	6	9	
标准起重高度 Standard lifting height(m)	1.5	1.5	1.5	1.5	1.5	
试验载荷 Testing load KN	11	22	37.5	75	135	
起重链条行数 Lifting chain lines	1	2	2	4	4	
满载时手扳力 Chain pull to lift full load N	140	220	240	260	360	
起重链条直径 Chain diameter	5	5	6	6	7.1	
收缩长 Contraction distance mm	200	350	350	650	750	
主要尺寸 Dimensions(mm)	A	148	172	172	200	200
	B	90	98	98	115	115
	C	136	160	160	180	225
	D	40	44	46	50	64
	H	320	380	380	480	600
	L	280	410	410	410	410
	K	27	34	36	38	48
伸缩长 Stretch distance mm	1800	1850	1850	2150	2250	
净重 Net weight kg	4.7	5.7	9.8	19	24	
起重高度每增加1米增加重量 (kg) Extra weight per meter of extra lift	0.55	1.1	1.5	3	3.6	



SLH-CSL 铝合金手拉葫芦
SLH-CSL aluminum alloy chain hoist

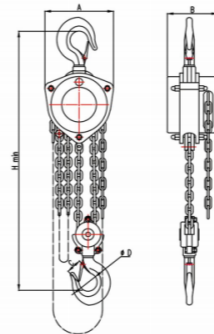

型号 Model	SLH-0.5CSL	SLH-1CSL	SLH-1.5CSL	SLH-2CSL	SLH-3CSL	SLH-5CSL	
起重重量 Capacity(kg)	500	1000	1500	2000	3000	5000	
起重高度 Lifting height(m)	3	3	3	3	3	3	
实验载荷 Testing load (kg)	625	1250	1875	2500	3750	6250	
起重链条行数 No. of load chain falls	1	1	1	2	2	3	
手拉链条规格 Type of hand chain mm	φ5X23.7						
起重链条规格 Type of load chain mm	φ5X15	φ6.3X19	φ8X24	φ6.3X19	φ8X24	φ8X24	
两钩间最小距离(毫米) hmin headroom(hook tohook)Hmin(mm)	283	353	441	476	553	609	
手拉链条长度: L Length of hand chain	3	3	3	3	3	3	
尺寸 Dimension(mm)	A	113	137	142	137	142	
	B	66	78	76	78	76	76
	C	145	173	216	173	204	269
	D	18	25	30	33	36	43
	E	20	26	29	35	37	44
产品净重(不含链条) Net weight kg	4.5	6	11.2	8.6	13.8	22.1	
手拉链条(3m)重量 Hand chain weight kg	3.1	3.1	3.1	3.1	3.1	3.1	
起重链条重量 Load chain weight kg	1.7	2.8	4.7	5.5	9.2	13.7	



SLH-CSL 铝合金手扳葫芦
SLH-CSL aluminum alloy lever hoist

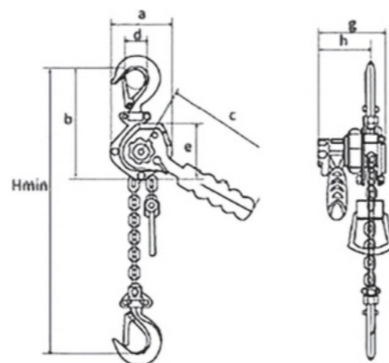

型号 Model	250Kg	500Kg	750Kg	1500Kg	3000Kg	6000Kg
牵引力 Tractive Force	550 Pound	1100 Pound	1650 Pound	3300 Pound	6600 Pound	13200 Pound
起重高度 Lifting Height	1.5 M	1.5 M	1.5 M	1.5 M	1.5 M	1.5 M
实验载荷 Experimental Load	375Kg	750Kg	1125Kg	2250Kg	4500Kg	9000Kg
满载手扳力 Fully Loaded Wrench Force	260N	260N	220N	240N	350N	380N
起重链条行数 Number of Lifting Chain Rows	12	12	15	21	27	27
链条直径 Diamater of Chains	4Mm	4Mm	5Mm	7Mm	9Mm	9Mm
每增加一米时的重量 Weight Per Additional Meter	0.346Kg	0.346Kg	0.541Kg	1.1Kg	1.8Kg	1.8Kg
净重 Net Weight	2.2Kg	3.2Kg	4.7Kg	7.6Kg	14Kg	22Kg
打包重量 Packaged Weight	2.4Kg	3.4Kg	5Kg	8Kg	14.5Kg	22.5Kg
包装尺寸 Package Size	21*12.5*11.5 Cm	23.5*13.5*12 Cm	30*14*14.5 Cm	33*18*15.7 Cm	40*20*19 Cm	49.5*23.5*21.5 Cm



Material Handling Equipment



Chain Hoist



Electric Wire Rope Hoist



Beam Clamps



Lifting Tools



Lifting Tools